

Off-Line Digital Green-Mode PWM Controller Integrated with Power BJT

1.0 Features

- Tight constant voltage and constant current regulation with PrimAccurate™ primary-side-only feedback
- AccuSwitch™ technology with integrated 800V bipolar junction transistor (BJT)
- Primary-side sensing technology eliminates opto-isolators and simplifies design
- DIP package for higher power and for single-sided board
- Adaptively controlled soft start-up enables fast and smooth start-up for a wide range of output voltage (5V, 12V and above) and capacitive loads up to 6,000µF
- 64kHz PWM switching frequency
- No-load power consumption < 30mW at 230V_{AC} with typical 5V application circuit
- Fast dynamic load response for both one-time and repetitive load transients
- Adaptive multi-mode PWM/PFM control improves efficiency
- Quasi-resonant operation for highest overall efficiency
- EZ-EMI® design easily meets global EMI standards
- No external compensation components required
- Built-in single-point fault protections against output short circuit, output over-voltage, and current-sense-resistor short-circuit faults
- Built-in over-temperature protection (OTP)
- No audible noise over entire operating range

2.0 Description

The iW1817 is a high performance AC/DC power supply control device which uses digital control technology to build peak-current mode PWM flyback power supplies. This device includes an internal power BJT and operates in quasi-resonant mode to provide high efficiency along with a number of key built-in protection features while minimizing the external component count, simplifying EMI design, and lowering the total bill of material cost. The iW1817 uses iWatt's advanced PrimAccurate™ primary-side sensing technology to eliminate the need for secondary feedback circuitry, while achieving excellent line and load regulation. It also eliminates the need for loop compensation components while maintaining stability in all operating conditions. The pulse-by-pulse waveform analysis allows for fast dynamic load response for both one-time and repetitive load transients. The built-in power limit function enables optimized transformer design for a wide input voltage range.

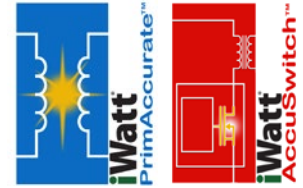

iWatt's innovative proprietary technology ensures that power supplies built with the iW1817 can achieve highest average efficiency, lowest standby power consumption, and fast smooth startup with a wide range of output voltage (5V, 12V and above) and capacitive loads (from 330µF to 6,000µF).

3.0 Applications

- Low-power AC/DC power supply for smart meters, motor control, home appliances, networking devices and industrial applications
- Linear AC/DC replacement



Off-Line Digital Green-Mode PWM Controller Integrated with Power BJT

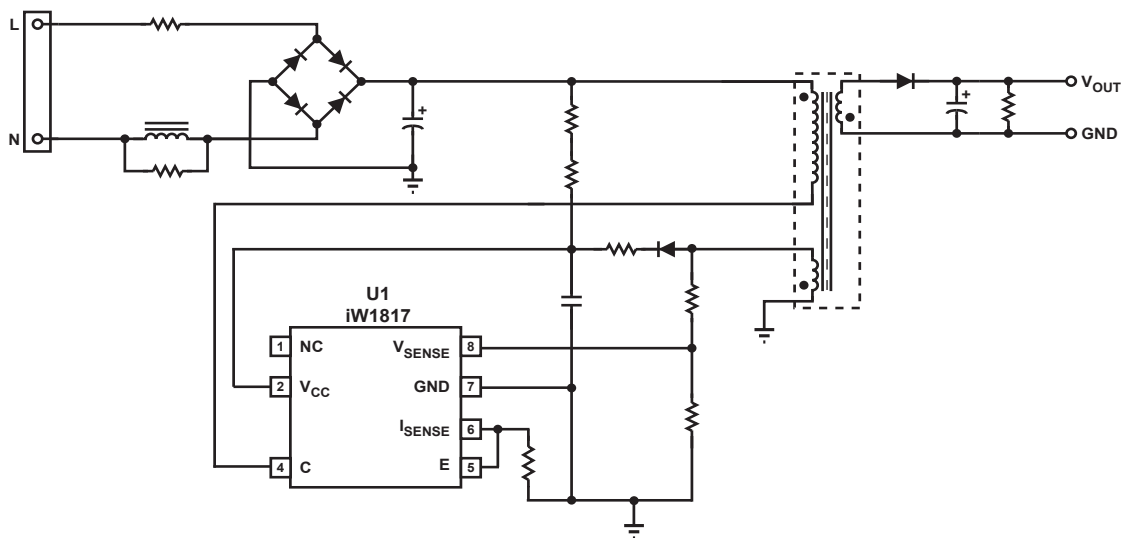

WARNING:

The iW1817 is intended for high voltage AC/DC offline applications. Contact with live high voltage offline circuits or improper use of components may cause lethal or life threatening injuries or property damage. Only qualified professionals with safety training and proper precaution should operate with high voltage offline circuits.

Figure 3.1 : iW1817 Typical Application Circuit

iW1817 Output Power Table at Universal Input (85V_{AC}–264V_{AC})

Condition	Open Frame ¹
Output Power (W)	7.0

Notes:

1. Maximum practical continuous output power measured at open frame ambient temperature of 50°C and device pins/ package temperatures of ≤ 100°C while minimum bulk capacitor voltage is kept above 90V_{DC} and no special heatsinking is used (test unit is placed in a non-ventilated environment).
2. The output power capability can vary depending on the power supply system designs and operating conditions. See Section 10.14 for more details.

Off-Line Digital Green-Mode PWM Controller Integrated with Power BJT

4.0 Pinout Description

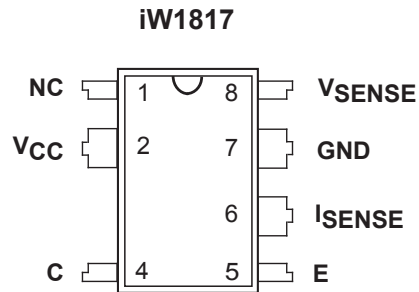

Figure 4.1: 7-Lead PDIP Package

Pin #	Name	Type	Pin Description
1	NC	No Conneciton	No connection.
2	V _{CC}	Power Input	Power supply for control logic.
4	C	BJT Collector	Collector of internal BJT.
5	E	BJT Emitter	Emitter of internal BJT (pin 5 and pin 6 must be shorted externally on the PCB).
6	I _{SENSE}	Analog Input	Primary current sense. Used for cycle-by-cycle peak current control and current limit.
7	GND	Ground	Ground.
8	V _{SENSE}	Analog Input	Auxiliary voltage sense (used for primary-side regulation).

Off-Line Digital Green-Mode PWM Controller Integrated with Power BJT

5.0 Absolute Maximum Ratings

Absolute maximum ratings are the parameter values or ranges which can cause permanent damage if exceeded. For maximum safe operating conditions, refer to Electrical Characteristics in Section 7.0. ($T_A = 25^\circ\text{C}$, unless otherwise noted). Proper design precautions must be made to ensure that the internal die junction temperature of the iW1817 does not exceed 150°C . Otherwise permanent damage to the device may occur.

Parameter	Symbol	Value	Units
DC supply voltage range (pin 2, $I_{CC} = 20\text{mA max}$)	V_{CC}	-0.3 to 18	V
Continuous DC supply current at V_{CC} pin ($V_{CC} = 15\text{V}$)	I_{CC}	20	mA
V_{SENSE} input (pin 8, $I_{V_{sense}} \leq 10\text{mA}$)		-0.7 to 4.0	V
I_{SENSE} input (pin 6)		-0.3 to 4.0	V
ESD rating per JEDEC	HBM	2000	V
	MM	200	
	CDM	1000	
Latch-up test per JESD78A		± 100	mA
Collector-Emitter breakdown voltage (Emitter and base shorted together; $I_C = 1\text{mA}$, $R_{EB} = 0\Omega$)	V_{CES}	800	V
Collector current ¹	I_C	1.5	A
Collector peak current ¹ ($t_p < 1\text{ms}$)	I_{CM}	3	A
Maximum junction temperature	T_{JMAX}	150	$^\circ\text{C}$
Storage temperature	T_{STG}	-55 to 150	$^\circ\text{C}$

Notes:

Note 1. Limited by maximum junction temperature.

6.0 Thermal Characteristics

Parameter	Symbol	Value	Units
Thermal Resistance Junction-to-Ambient ¹ (Dissipated power 0.9W)	θ_{JA}	103	$^\circ\text{C/W}$
Thermal Resistance Junction-to-GND pin (pin 7) ² (Dissipated power 0.9W)	ψ_{JB}	26	$^\circ\text{C/W}$
Thermal Resistance Junction-to-Collector pin (pin 4) ² (Dissipated power 0.9W)	ψ_{J-BJT}	13	$^\circ\text{C/W}$
Thermal Shutdown Threshold ³	T_{SD}	150	$^\circ\text{C}$
Thermal Shutdown Recovery ³	T_{SD-R}	100	$^\circ\text{C}$

Notes:

- θ_{JA} is measured in a one-cubic-foot natural convection chamber.
- ψ_{JB} [Psi Junction to Board] provides an estimation of the die junction temperature relative to the PCB [Board] surface temperature. ψ_{J-BJT} [Psi Junction to Collector pin] provides an estimation of the die junction temperature relative to the collector pin [internal BJT Collector] surface temperature. ψ_{JB} is measured at the ground pin (pin 7) without using any thermal adhesives. See Section 10.14 for more information.
- These parameters are typical and they are guaranteed by design.

Off-Line Digital Green-Mode PWM Controller Integrated with Power BJT

7.0 Physical Dimensions

7-Lead Plastic Dual In-Line (PDIP) Package

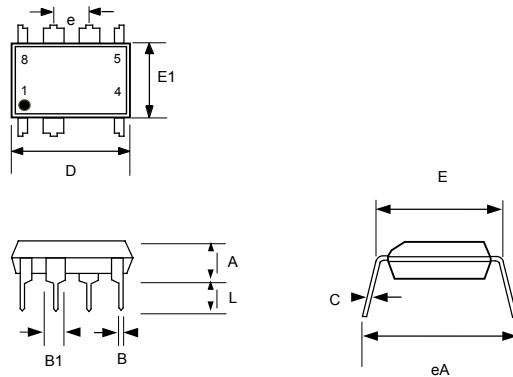

Symbol	Inches		Millimeters	
	MIN	MAX	MIN	MAX
A	0.135	0.145	3.429	3.683
B	0.015	0.021	0.381	0.533
B1	0.050	0.065	1.270	1.650
C	0.007	0.014	0.200	0.356
D	0.367	0.387	9.322	9.830
E	0.300	0.325	7.620	8.255
E1	0.240	0.260	6.096	6.604
e	0.1 BSC		2.54 BSC	
eA	0.332	0.392	8.433	9.957
L	0.120	0.140	3.048	3.556

Compliant to JEDEC Standard MS12F

Controlling dimensions are in inches; millimeter dimensions are for reference only

This product is RoHS compliant and Halide free.

Soldering Temperature Resistance:

[a] Package is IPC/JEDEC Std 020D Moisture Sensitivity Level 1

[b] Package exceeds JEDEC Std No. 22-A111 for Solder Immersion Resistance; package can withstand 10 s immersion < 260°C

Dimension D does not include mold flash, protrusions or gate burrs. Mold flash, protrusions or gate burrs shall not exceed 0.15 mm per end. Dimension E1 does not include interlead flash or protrusion. Interlead flash or protrusion shall not exceed 0.25 mm per side.

The package top may be smaller than the package bottom. Dimensions D and E1 are determined at the outermost extremes of the plastic body exclusive of mold flash, tie bar burrs, gate burrs and interlead flash, but including any mismatch between the top and bottom of the plastic body.

8.0 Ordering Information

Part Number	Package	Description
iW1817-00	PDIP-7	Tube ¹

Note 1: Packing quantity is 50 units/tube, 1,000 units (20 tubes)/box. Minimum ordering quantity is 1,000 units.

Off-Line Digital Green-Mode PWM Controller Integrated with Power BJT

Disclaimer

Information in this document is believed to be accurate and reliable. However, Dialog Semiconductor does not give any representations or warranties, expressed or implied, as to the accuracy or completeness of such information. Dialog Semiconductor furthermore takes no responsibility whatsoever for the content in this document if provided by any information source outside of Dialog Semiconductor.

Dialog Semiconductor reserves the right to change without notice the information published in this document, including without limitation the specification and the design of the related semiconductor products, software and applications.

Applications, software, and semiconductor products described in this document are for illustrative purposes only. Dialog Semiconductor makes no representation or warranty that such applications, software and semiconductor products will be suitable for the specified use without further testing or modification. Unless otherwise agreed in writing, such testing or modification is the sole responsibility of the customer and Dialog Semiconductor excludes all liability in this respect.

Customer notes that nothing in this document may be construed as a license for customer to use the Dialog Semiconductor products, software and applications referred to in this document. Such license must be separately sought by customer with Dialog Semiconductor.

All use of Dialog Semiconductor products, software and applications referred to in this document are subject to Dialog Semiconductor's [Standard Terms and Conditions of Sale](#), unless otherwise stated.

© Dialog Semiconductor (UK) Ltd. All rights reserved.

RoHS compliance

Dialog Semiconductor complies to European Directive 2001/95/EC and from 2 January 2013 onwards to European Directive 2011/65/EU concerning Restriction of Hazardous Substances (RoHS/RoHS2).

Dialog Semiconductor's statement on RoHS can be found on the customer portal <https://support.diasemi.com/>. RoHS certificates from our suppliers are available on request.

Contacting Dialog Semiconductor

United Kingdom

Dialog Semiconductor (UK) Ltd
Phone: +44 1793 757700

Germany

Dialog Semiconductor GmbH
Phone: +49 7021 805-0

The Netherlands

Dialog Semiconductor B.V.
Phone: +31 73 640 88 22

Email

info_pcbg@diasemi.com

North America

Dialog Semiconductor Inc.
Phone: +1 408 845 8500

Japan

Dialog Semiconductor K. K.
Phone: +81 3 5425 4567

Taiwan

Dialog Semiconductor Taiwan
Phone: +886 8178 6222

Web site:

www.dialog-semiconductor.com

Singapore

Dialog Semiconductor Singapore
Phone: +65 64849929

Hong Kong

Dialog Semiconductor Hong Kong
Phone: +852 2607 4271

Korea

Dialog Semiconductor Korea
Phone: +82 2 3469 8200

China

*Dialog Semiconductor
(Shenzhen)*
Phone: +86 755 2981 3669

*Dialog Semiconductor
(Shanghai)*
Phone: +86 21 5178 2561